

MIRA[®] BB-86 Counterbore Unit

Recuts Diesel Sleeve Counterbores

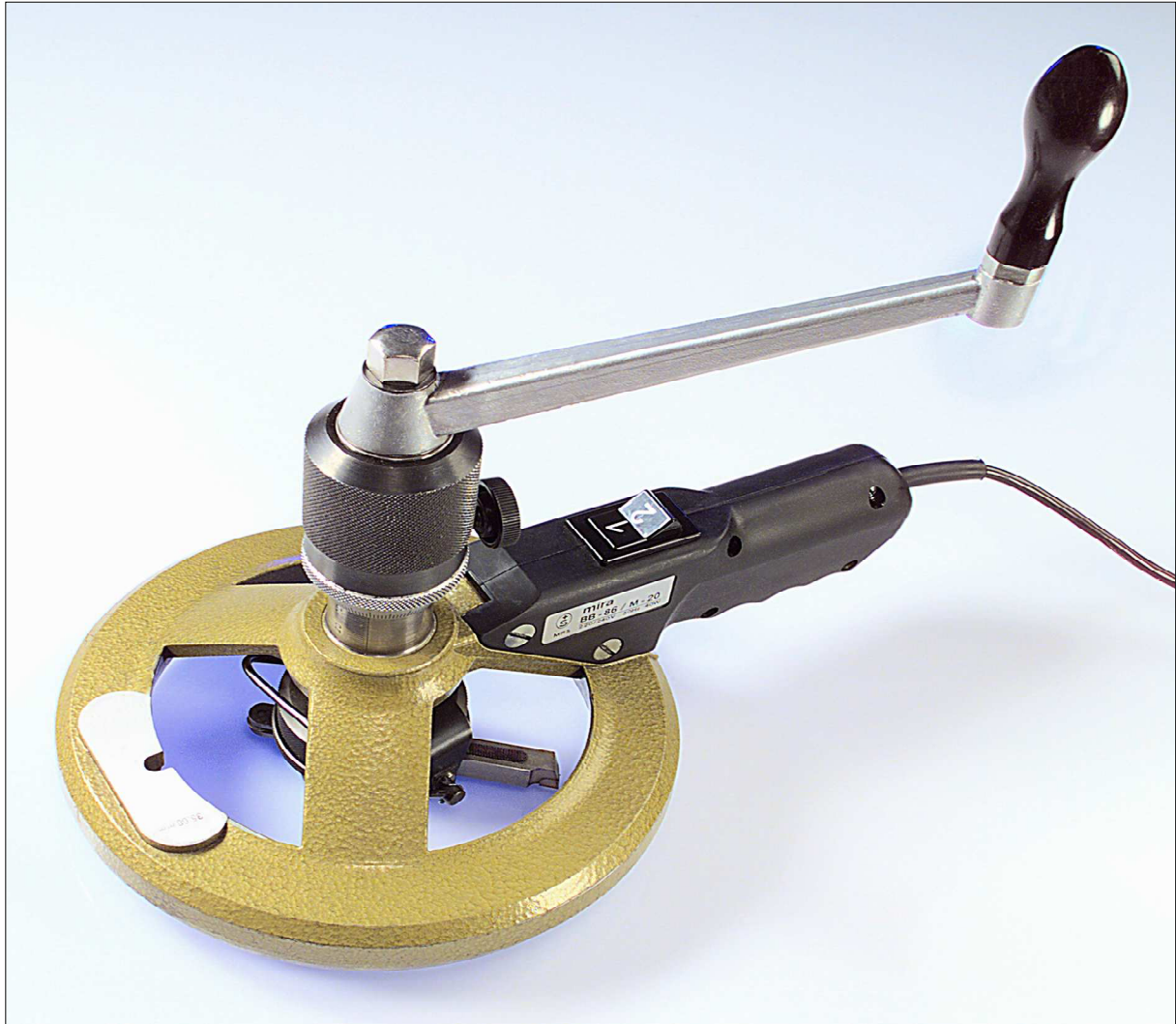

Available as BB-86 Standard 170mm Unit or BB-86 „Giant“ with 198mm Inside Diameter !

To guarantee a perfect seal between engine block and wet liners, the counterbore seats in an engine block must be refaced during engine overhaul and in case of leaks. This job is rapidly and simply carried out with the very accurate BB unit. Its centering is automatic and the unit is clamped by means of an electro magnet. As the unit is placed directly on the sealing surface of an engine block, the refaced counterbore seats will automatically be parallel with the sealing surface. The refacing procedures can be carried out on installed as well as on removed engine blocks or even built-in underfloor engines.

Order Numbers: BB-86 or BB-86 „Giant“

Precise & Quickly - Ask for a Detailed Offer !

MIRA[®] BB-86 Counterbore Unit

Fully Portable - Simple to Operate

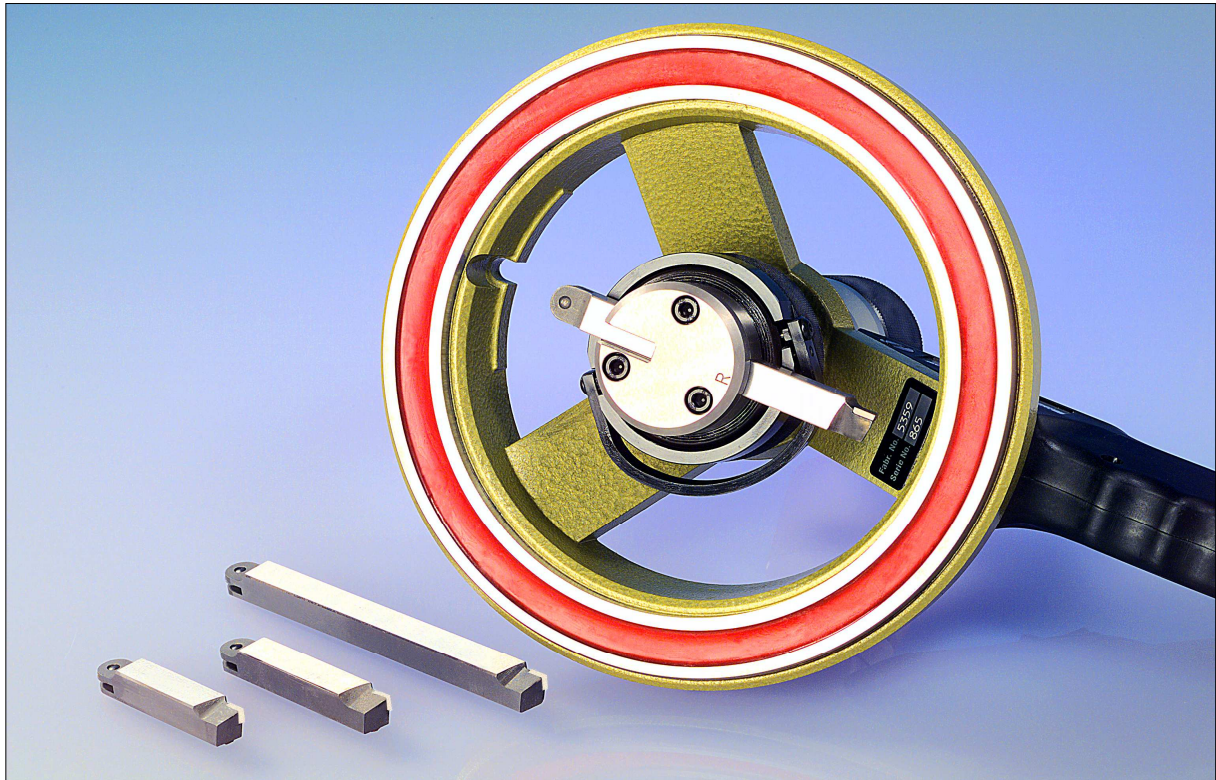

Powerful Electro Magnetic Base

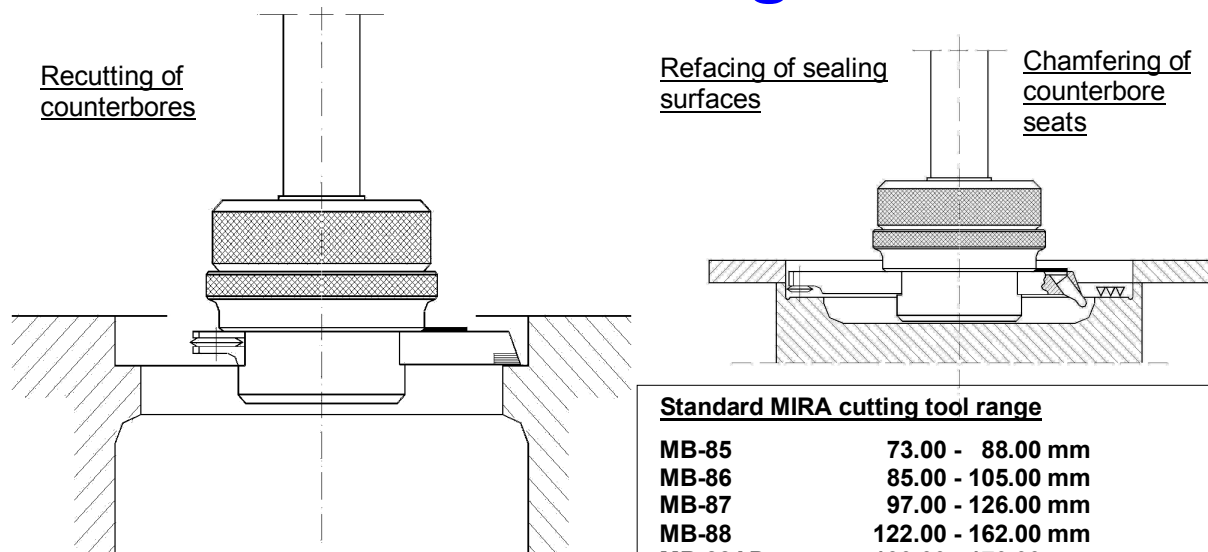

For deep seated counterbores, a special extension shaft (220mm) is available.

Standard MIRA cutting tool range

MB-85	73.00 - 88.00 mm
MB-86	85.00 - 105.00 mm
MB-87	97.00 - 126.00 mm
MB-88	122.00 - 162.00 mm
MB-88AD	130.00 - 170.00 mm
MB-89*	158.00 - 198.00 mm
MB-90*	194.00 - 225.00 mm

* In combination with an intermediate steel plate !

Special Tooling and Extension Kit on Request !